

Weld-in thermowell (solid-machined)

Socket-weld design

Model TW20

WIKA data sheet TW 95.20

Applications

- Petrochemical industry, on-/offshore, plant construction
- For high process loads

Special features

- Different dimensions for standardised welding sockets
- International standard
- Possible thermowell forms:
 - Model TW20-A: tapered
 - Model TW20-B: straight
 - Model TW20-C: stepped
 - "Quill Tip" version (with open tip)



Weld-in thermowell model TW20

Description

Each thermowell is an important component of any temperature measurement point. It is used to separate the process from the surrounding area, thus protecting the environment and operating personnel and keeps aggressive media, high pressures and flow rates from the temperature sensor itself and thereby enables the thermometer to be exchanged during operation.

Based on the almost limitless application possibilities, there are a large number of variants, such as thermowell designs or materials. The type of process connection and the basic method of manufacture are important design differentiation criteria. A basic differentiation can be made between threaded and weld-in thermowells, and those with flange connections.

Furthermore, one can differentiate between fabricated and solid-machined thermowells. Fabricated thermowells are constructed from a tube, that is closed at the tip by a welded solid tip. Solid-machined thermowells are manufactured from barstock.

The TW20 series of solid-machined weld-in thermowells are suitable for use with numerous electrical and mechanical thermometers from WIKA.

Due to the heavy-duty design, these international design thermowells are the first choice for use the chemical and petrochemical industries and in plant construction.

Standard version

Thermowell materials

Stainless steel 304/304L, 316/316L, 1.4571
A105, special materials

Process connection

Ø 26.7 mm, Ø 33.4 mm, Ø 48.3 mm

Connection to thermometer

½ NPT, G ½ (female)

“Quill Tip” version with weld-in connection ½" and ¾"

Bore size

Ø 6.6 mm, Ø 8.5 mm

Insertion length U

To customer specification

Connection length H

To customer specification

Max. process temperature, process pressure

Depending on

- Thermowell design
 - Dimensions
 - Material
- Process conditions
 - Flow rate
 - Density of medium

Options

- Other dimensions and materials
- “Quill Tip” version
- Quality certificates
- Wake frequency calculation to ASME PTC 19.3 TW-2016 is recommended in critical applications as a WIKA engineering service

For further information see Technical information IN 00.15
“Wake frequency calculation”.

Dimensions in mm

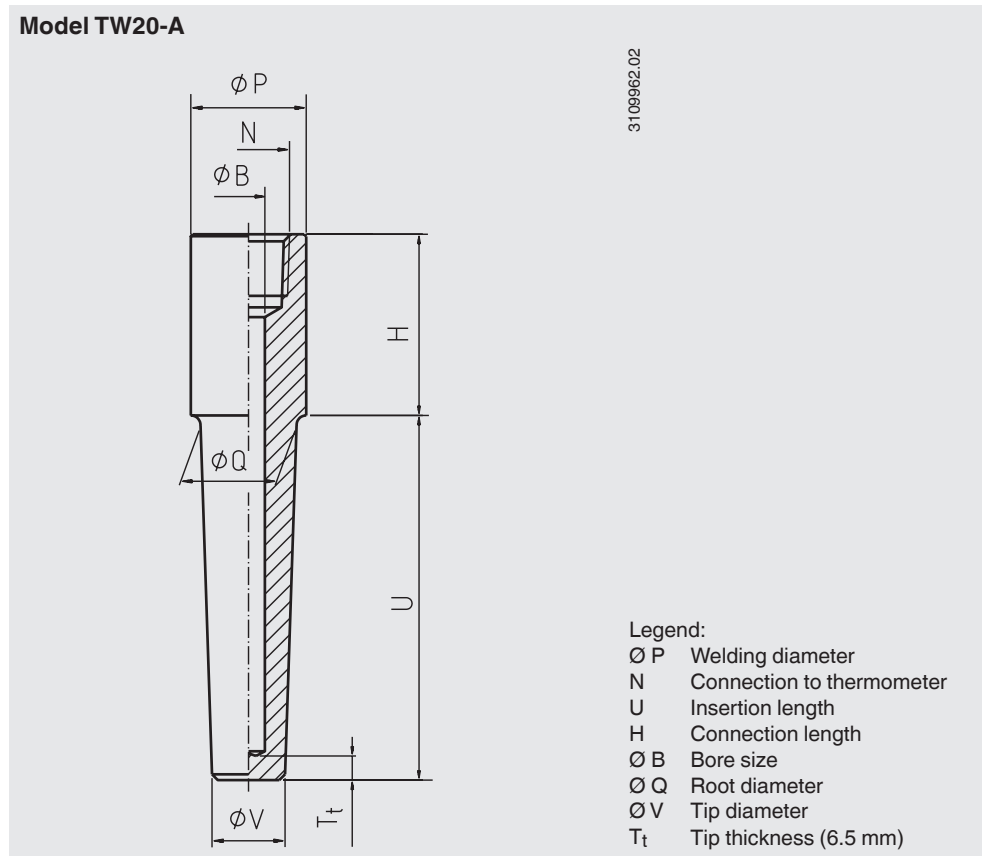

“Quill Tip” version

Standard

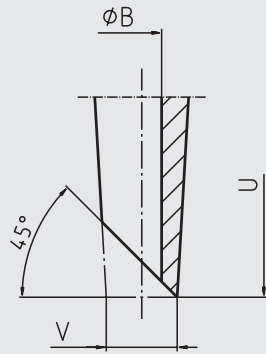

Option: straight

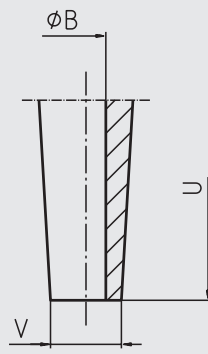

11536128.01

Tapered thermowell form

Dimensions in mm					Weight in kg (for H = 45 mm)	
Ø P	N	Ø Q	Ø V	Ø B	U = 100 mm	U = 560 mm
26.7	½ NPT, G ½	19	16	6.6 or 8.5	0.4	1.1
33.4	½ NPT, G ½	25	19	6.6 or 8.5	0.6	1.9
48.3	½ NPT, G ½	38	19	6.6 or 8.5	1.2	3.5

Suitable stem lengths (dial thermometers)

Connection type	Stem length l_1
S, 4, 5	$l_1 = U + H - 10 \text{ mm}$
2	$l_1 = U + H - 30 \text{ mm}$

Ordering information

Model / Thermowell form / Welding diameter P / Connection to thermometer / Insertion length U / Connection length H / Thermowell material / Bore diameter Ø B / Root diameter Ø Q / Tip diameter Ø V / Assembly with thermometer / Certificates / Options

© 12/2007 WIKA Alexander Wiegand SE & Co. KG, all rights reserved.
The specifications given in this document represent the state of engineering at the time of publishing.
We reserve the right to make modifications to the specifications and materials.

