

In-line diaphragm seal with sterile connection With clamp connection (Tri-clamp) Models 981.22, 981.52 and 981.53

WIKA data sheet DS 99.52



for further approvals
see page 4

Applications

- Sanitary applications
- Gases, compressed air, vapour; liquid, powdery and crystallising media
- For flowing, pure media
- Ultra-pure steam systems
- Pressure/vacuum monitoring, e.g. filter monitoring

Special features

- For direct, quickly removable installation in pipelines
- Self-draining in all mounting positions
- Quick cleaning, without residue
- Suitable for SIP and CIP
- Dead-space free installation in pipes

Description

Diaphragm seals are used for the protection of pressure measuring instruments in applications with difficult media. In diaphragm seal systems, the diaphragm of the diaphragm seal effects the separation of the instrument and the medium. The pressure is transmitted to the measuring instrument via the system fill fluid which is inside the diaphragm seal system.

For the implementation of demanding customer applications, there is a wide variety of designs, materials and system fill fluids available.

For further technical information on diaphragm seals and diaphragm seal systems see IN 00.06 "Application, operating principle, designs".

The model 981.22, 981.52 and 981.53 in-line diaphragm seals are suitable for use in the measurement of flowing media. In addition to avoiding potential blockages in the process, inline measurement technology also contributes to



In-line diaphragm seal, model 981.22

securing product quality, mainly through its perfect cleanability. Due to the continuous cylindrical diaphragm, the measuring locations feature neither dead spaces nor non-flushable branches. The good cleanability of the in-line diaphragm seals has been tested and confirmed by independent institutions (e.g. EHEDG, Bio Processing Institute). The diaphragm seals can withstand the cleaning vapour temperatures occurring in the SIP processes and thus ensure a sterile connection between the medium to be measured and the diaphragm seal.

Mounting of the diaphragm seal to the measuring instrument may be made via a direct connection, for high temperatures via a cooling element or via a flexible capillary.

The availability of in-line diaphragm seals for common pipe standards and nominal widths simplifies integration into already existing pipe cross-sections.

Specifications

Models 981.22, 981.52 and 981.53	Standard	Option
Pressure range	0 ... 0,6 bar to 0 ... 40 bar [0 ... 8.7 psi to 0 ... 580 psi] ¹⁾ or all other equivalent vacuum or combined pressure and vacuum ranges	
Level of cleanliness of wetted parts	Oil and grease free per ASTM G93-03 level F WIKA standard (< 1,000 mg/m ²)	<ul style="list-style-type: none"> ■ Oil and grease free per ASTM G93-03 level D and ISO 15001 (< 220 mg/m²) ■ Oil and grease free per ASTM G93-03 level C and ISO 15001 (< 66 mg/m²)
Origin of wetted parts	International	EU, CH, USA
Surface roughness of wetted parts	Ra ≤ 0.76 µm [30 µin] per ASME BPE SF3 (except for weld seam)	Ra ≤ 0.38 µm [15 µin] per ASME BPE SF4, only with electropolished surface (except for weld seam)
Connection to the measuring instrument	Axial gauge adapter	Axial gauge adapter with G ½, G ¼, ½ NPT or ¼ NPT (female)
Type of mounting	Direct mounting	<ul style="list-style-type: none"> ■ Capillary ■ Cooling element
Vacuum service (see IN 00.25)	Basic service	<ul style="list-style-type: none"> ■ Premium service ■ Advanced service
Marking of the diaphragm seal	-	Per valid 3-A standard
Instrument mounting bracket (only for capillary option)	-	<ul style="list-style-type: none"> ■ Form H per DIN 16281, 100 mm, aluminium, black ■ Form H per DIN 16281, 100 mm, stainless steel ■ Bracket for pipe mounting, for pipe Ø 20 ... 80 mm, steel (see data sheet AC 09.07)

1) Higher nominal pressures on request (for maximum pressure range consider pressure rating of clamp closure)

Installation example, model 981.22 directly mounted to model PSD-4 pressure switch

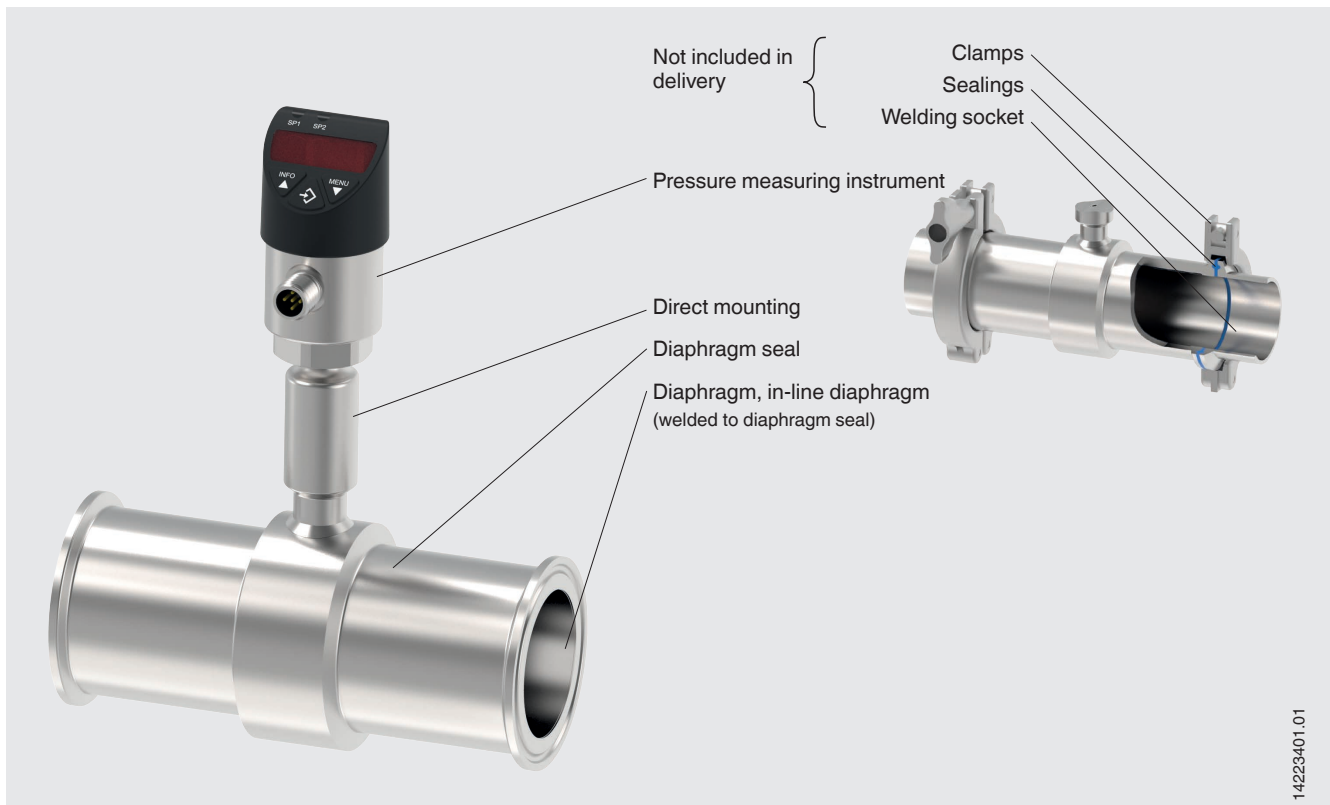

Mounting variants for pressure gauges

For horizontal pipelines

Variant 1

- Connection: Lower mount
- Pointer shaft: Crosswise to flow direction
- Mounting: Direct mounting, horizontal pipeline

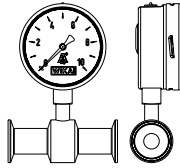

Variant 2

- Connection: Lower mount
- Pointer shaft: Parallel to flow direction
- Mounting: Direct mounting, horizontal pipeline

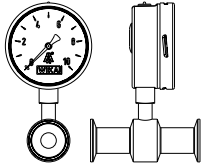

Variant 3

- Connection: Lower back mount
- Pointer shaft: Crosswise to flow direction
- Mounting: Direct mounting, horizontal pipeline

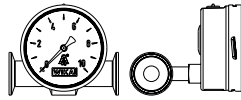

Variant 4

- Connection: "At 12 o'clock"
- Pointer shaft: Crosswise to flow direction
- Mounting: Direct mounting, horizontal pipeline

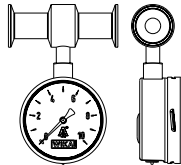

For vertical pipelines

Variant 1

- Connection: "At 12 o'clock"
- Pointer shaft: Crosswise to flow direction
- Mounting: Direct mounting, vertical pipeline

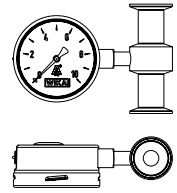

Variant 2

- Connection: "At 12 o'clock"
- Pointer shaft: Crosswise to flow direction
- Mounting: Direct mounting, vertical pipeline

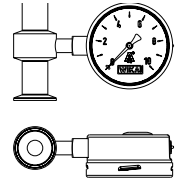

Variant 3

- Connection: Lower back mount
- Pointer shaft: Crosswise to flow direction
- Mounting: Direct mounting, vertical pipeline

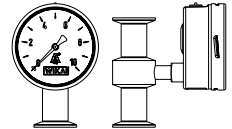





Material combinations

Upper body of diaphragm seal	Wetted parts (diaphragm) ¹⁾
Stainless steel 1.4435 (316L)	Stainless steel 1.4435 (316L)
Stainless steel 1.4435 (316L), electropolished ²⁾	Stainless steel 1.4435 (316L), electropolished ²⁾
Hastelloy C22 (2.4602)	Hastelloy C22 (2.4602)
Hastelloy C276 (2.4819)	Hastelloy C276 (2.4819)

1) Marking of the parts with the material code guarantees 100 % material traceability
 2) Only in connection with a surface roughness of $R_a \leq 0.38 \mu\text{m}$ for the wetted parts

Further material combinations for special process temperatures on request.

Approvals

Logo	Description	Country
	EU declaration of conformity Pressure equipment directive	European Union
	EAC (option) Pressure equipment directive	Eurasian Economic Community
	3-A Sanitary Standard	USA
	EHEDG ¹⁾ Hygienic Equipment Design	European Union
-	CRN Safety (e.g. electr. safety, overpressure, ...)	Canada
-	MTSCHS (option) Permission for commissioning	Kazakhstan

1) EHEDG conformity only in combination with ASEPTO-STAR k-flex upgrade, sealing from Kieselmann GmbH.

Certificates (option)

- 2.2 test report per EN 10204
 - State-of-the-art manufacturing, material proof, indication accuracy for diaphragm seal systems
 - FDA conformity of the system fill fluid
 - 3-A conformity of the diaphragm seal, based on a third party verification
 - Manufacturer's declaration for food contact materials regarding regulation (EC) No. 1935/2004
- 3.1 inspection certificate per EN 10204
 - Material proof, wetted metal parts
 - Indication accuracy for diaphragm seal systems
- Manufacturer's declaration for food contact materials regarding regulation (EC) No. 1935/2004
- Others on request

Approvals and certificates, see website

Model 981.22

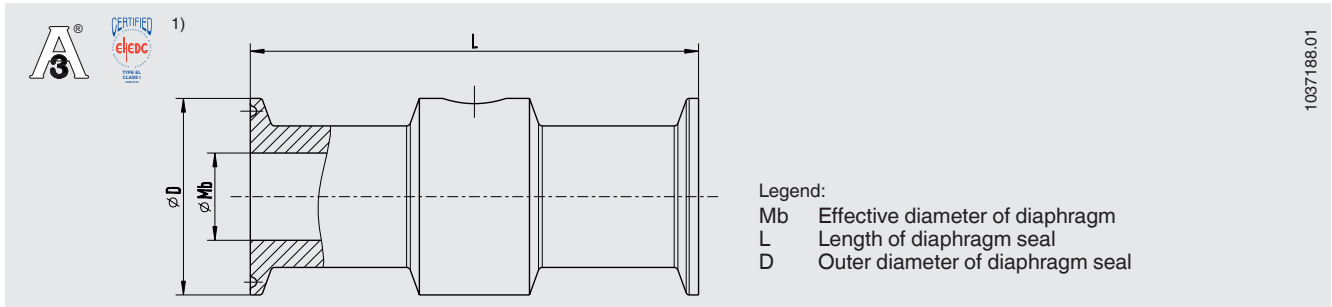

Process connection: Clamp connection per DIN 32676

Pipe standard per DIN 11866 row B and ISO 1127 row 1

DN	PN ²⁾	Dimensions in mm [in]				
		For pipe outer Ø x wall thickness	L	D	Mb	
13.5	40	13.5 x 1.6 [0.531 x 0.063]	114 [4.488]	25 [0.984]	10.3 [0.406]	
17.2		17.2 x 1.6 [0.677 x 0.063]			14.0 [0.551]	
21.3		21.3 x 1.6 [0.839 x 0.063]			18.1 [0.713]	
26.9		26.9 x 1.6 [1.059 x 0.063]				
33.7		33.7 x 2 [1.327 x 0.079]		146 [5.748]	64 [2.52]	23.7 [0.933]
42.4		42.4 x 2 [1.669 x 0.079]				29.7 [1.169]
48.3		48.3 x 2 [1.902 x 0.079]				38.4 [1.512]
60.3		60.3 x 2 [2.374 x 0.079]				44.3 [1.744]
76.1	25	76.1 x 2 [2.996 x 0.079]	156 [6.142]	77.5 [3.051]	56.3 [2.217]	
				91 [3.583]	72.1 [2.839]	

Process connection: Clamp connection per DIN 32676

Pipe standard: Pipes per DIN 11866 row C or ASME BPE

DN	PN ²⁾	Dimensions in mm [in]					
		For pipe outer Ø x wall thickness	L	D	Mb		
½"	40	12.7 x 1.6 [0.5 x 0.063]	114 [4.488]	25 [0.984]	9.55 [0.376]		
¾"		19.05 x 1.6 [0.75 x 0.063]			15.7 [0.618]		
1"		25.4 x 1.6 [1 x 0.063]			22.2 [0.874]		
1 ½"		38.1 x 1.6 [1.5 x 0.063]		34.9 [1.374]			
2"		50.8 x 1.6 [2 x 0.063]		146 [5.748]	64 [2.52]	47.6 [1.874]	
2 ½"		63.5 x 1.6 [2.5 x 0.063]		156 [6.142]		77.5 [3.051]	60.3 [2.374]
3"		76.2 x 1.6 [3 x 0.063]				91 [3.583]	73.0 [2.874]

Process connection: Clamp connection per DIN 32676

Pipe standard per BS4825 part 3 and O.D. tube

DN	PN ²⁾	Dimensions in mm [in]			
		For pipe outer Ø x wall thickness	L	D	Mb
1"	40	25.4 x 1.65 [1 x 0.065]	114 [4.488]	50.5 [1.988]	22.1 [0.78]
1 ½"		38.1 x 1.65 [1.5 x 0.065]	146 [5.748]		38.4 [1.512]
2"		50.8 x 1.65 [2 x 0.065]	156 [6.142]	64 [2.52]	47.5 [1.87]
2 ½"		63.5 x 1.65 [2.5 x 0.065]		77.5 [3.051]	60.2 [2.37]
3"	25	76.2 x 1.65 [3 x 0.065]		91 [3.583]	72.9 [2.87]

1) EHDG conformity only in combination with ASEPTO-STAR k-flex upgrade, sealing from Kieselmann GmbH.

2) For maximum pressure range consider pressure rating of clamp.

Further dimensions and higher nominal pressures on request

Model 981.52

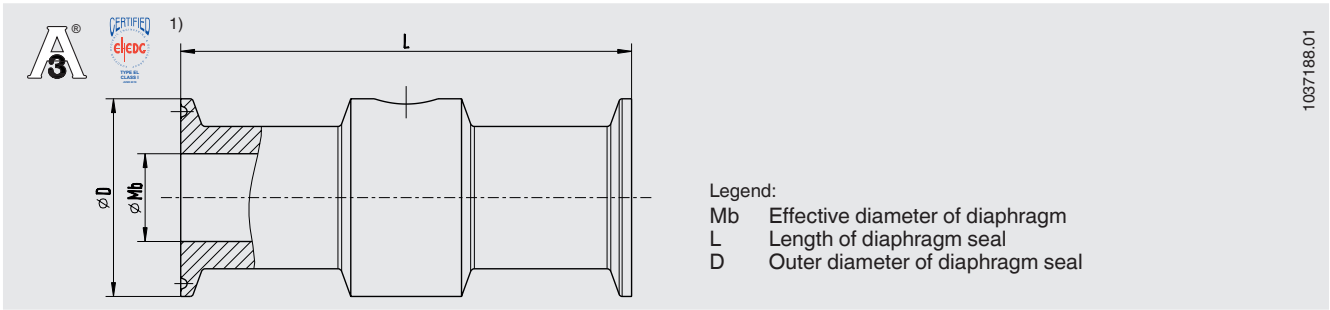

Process connection: Clamp connection per DIN 32676
Pipe standard per DIN 11866 row A and DIN 11850 row 2

DN	PN ²⁾	Dimensions in mm [in]			
		For pipe outer Ø x wall thickness	L	D	Mb
25	40	29 x 1.5 [1.142 x 0.059]	114 [4.488]	50.5 [1.988]	26 [1.024]
32		35 x 1.5 [1.378 x 0.059]			32 [1.26]
40		41 x 1.5 [1.614 x 0.059]			38 [1.496]
50		53 x 1.5 [2.087 x 0.059]	156 [6.142]		50 [1.969]
65	25	70 x 2 [2.756 x 0.079]	156 [6.142]	91 [3.583]	66 [2.598]
80		85 x 2 [3.346 x 0.079]			81 [3.189]
100		104 x 2 [4.094 x 0.079]			106 [4.173]
					119 [4.685]

1) EHEDG conformity only in combination with ASEPTO-STAR k-flex upgrade, sealing from Kieselmann GmbH.
 2) For maximum pressure range consider pressure rating of clamp.

Further dimensions and higher nominal pressures on request

Model 981.53

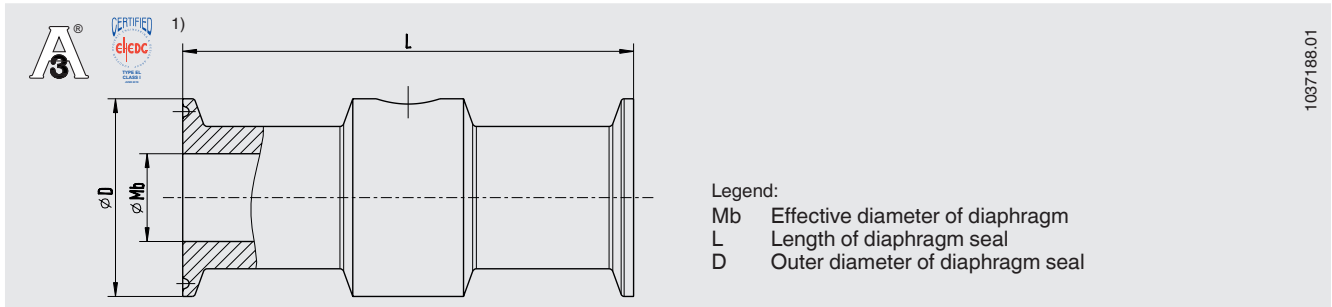

1037186.01

Process connection: Clamp connection per ISO 2852
Pipe standard per ISO 2037 and BS 4825 part 1

DN	PN ²⁾	Dimensions in mm [in]			
		For pipe outer \varnothing x wall thickness	L	D	Mb
25	40	25 x 1.2 [0.984 x 0.047]	114 [4.488]	50.5 [1.988]	22.6 [0.89]
28		28 x 1.2 [1.102 x 0.047]			25.6 [1.008]
33.7		33.7 x 1.2 [1.327 x 0.047]	146 [5.748]		31.3 [1.232]
38		38 x 1.2 [1.496 x 0.047]			35.6 [1.402]
40		40 x 1.2 [1.575 x 0.047]			64 [2.52]
51		51 x 1.2 [2.008 x 0.047]	156 [6.142]		48.6 [1.912]
63.5		63.5 x 1.6 [2.5 x 0.063]			7.5 [3.051]
70	70 x 1.6 [2.756 x 0.063]	91 [3.583]		66.8 [2.63]	
76.1	76.1 x 1.6 [2.996 x 0.063]			72.9 [2.87]	
88.9	25	88.9 x 2 [3.5 x 0.079]	106 [4.173]	84.9 [3.343]	
101.6		101.6 x 2 [4 x 0.079]		119 [4.685]	97.6 [3.843]

1) EHEDG conformity only in combination with ASEPTO-STAR k-flex upgrade, sealing from Kieselmann GmbH.
 2) For maximum pressure range consider pressure rating of clamp.

Further dimensions and higher nominal pressures on request

Ordering information

Diaphragm seal:

Diaphragm seal model / Process connection (type of process connection, pipe standard, pipe dimension) / Material (main body, diaphragm) / Surface roughness of wetted parts / Sealing / Zero point stabilisation (ZPS) / Connection to the measuring instrument / Level of cleanliness of wetted parts / Origin of wetted parts / Certificates

Diaphragm seal system:

Diaphragm seal model / Process connection (type of process connection, pipe standard, pipe dimension) / Material (main body, diaphragm) / Surface roughness of wetted parts / Sealing / Zero point stabilisation (ZPS) / Pressure measuring instrument model (per data sheet) / Mounting (direct mounting horizontal/vertical, cooling element horizontal/vertical, capillary) / min. and max. process temperature / min. and max. ambient temperature / Vacuum service / System fill fluid / Certificates / Height difference / Level of cleanliness of wetted parts / Origin of wetted parts / Instrument mounting bracket

© 11/2002 WIKA Alexander Wiegand SE & Co. KG, all rights reserved.
The specifications given in this document represent the state of engineering at the time of publishing.
We reserve the right to make modifications to the specifications and materials.



WIKAL Alexander Wiegand SE & Co. KG
Alexander-Wiegand-Straße 30
63911 Klingenberg/Germany
Tel. +49 9372 132-0
Fax +49 9372 132-406
info@wika.de
www.wika.de