

Single point load cell up to 2,000 kg Model F4817



WIKA data sheet FO 53.12

Applications

- Platform scales
- Filling scales
- Belt scales
- Packaging scales
- Dynamic testing system

Special features

- Measuring ranges 0 ... 100 kg up to 0 ... 2,000 kg
- Made of aluminium alloy
- High accuracy
- High side load tolerance
- Simple structure, easy to install



Single point load cell, model F4817

Description

Single point load cells are especially designed to be used in platform weighing. They can be mounted under the platform without any further construction or calibration processes.

The load cell is easy to operate due to its simple way of the force direction. It applied vertically to the load cell axis.

Note

The load cells are to be mounted on an even surface. The permitted load direction is marked with an arrow symbol.

Technical data in accordance with VDI/VDE/DKD 2638

Model F4817	
Nominal load F_{nom} kg	100 / 150 / 200 / 300 / 500 / 600 / 750 / 800 / 1,000 / 1,500 / 2,000
Relative linearity error d_{lin}	$\pm 0.02 \% F_{nom}$
Relative repeatability error in unchanged mounting position b_{rg}	$\pm 0.02 \% F_{nom}$
Relative reversibility v	$\leq \pm 0.02 \% F_{nom}$
Relative deviation of zero signal $d_{S,0}$	$\pm 2 \% F_{nom}$
Relative creep, 30 min.	$\pm 0.02 \% F_{nom}$
Temperature effect on zero signal TK_0	$\leq \pm 0.025 \% / 10^\circ C$
Temperature effect on characteristic value TK_C	$\leq \pm 0.025 \% / 10^\circ C$
Force limit F_L	150 % F_{nom}
Breaking force F_B	200 % F_{nom}
Material	Aluminium
Rated temperature range $B_{T, nom}$	-10 ... +40 °C
Operating temperature range $B_{T, G}$	-20 ... +60 °C
Input resistance R_e	410 \pm 10 Ω
Output resistance R_a	350 \pm 5 Ω
Insulation resistance R_{is}	$\geq 2,000 M\Omega / DC 100 V$
Output signal (rated output) C_{nom}	2.0 \pm 10 % mV/V
Electrical connection	Cable \varnothing 5 x 6,000 mm
Rated range of excitation voltage $B_{U, nom}$	10 V (max. 15 V)
Protection (acc. to IEC/EN 60529)	IP65
Platformsize	
■ up to 600 kg	800 x 1,000 mm
■ up to 750 kg	1,200 x 1,200 mm
Weight in kg	
■ up to 600 kg	1.4
■ up to 750 kg	4.7

Dimensions in mm

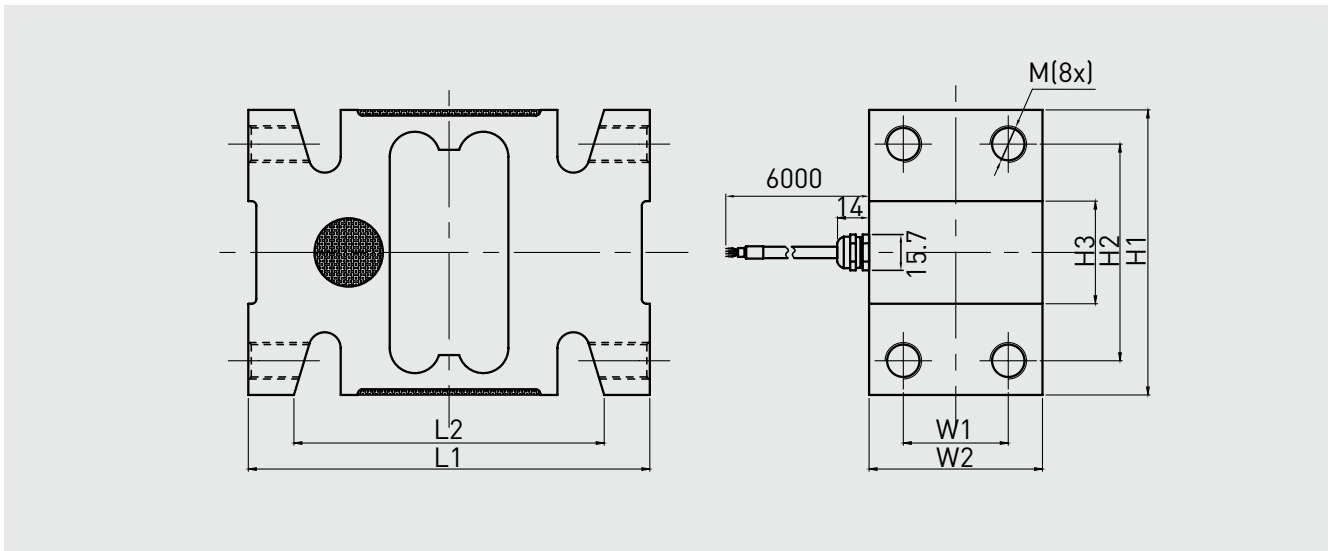

Nominal load in kg	Dimensions in mm							
	L1	L2	H1	H2	H3	W2	W1	M
100 / 150 / 200 / 300 / 500 / 600	140	-	75	50	30	46	25	M10
750 / 800 / 1,000 / 1,500 / 2,000	176	134	125	95	45	76	46	M16

Pin assignment

Electrical connection	
Excitation voltage (+)	Red
Excitation voltage (-)	Black
Signal (+)	Green
Signal (-)	White
Screen ⊕	Screen

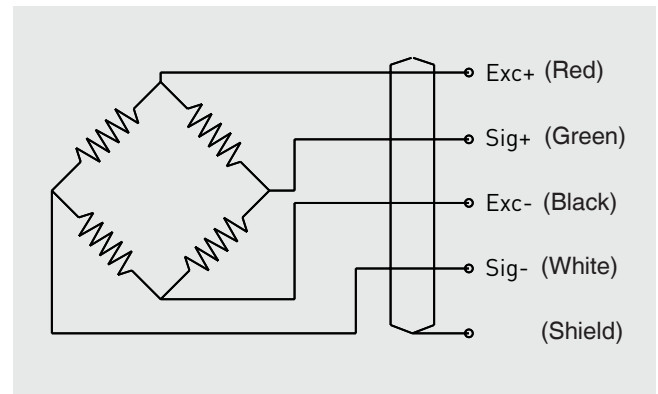

© 2016 WIKA Alexander Wiegand SE & Co. KG, all rights reserved.
The specifications given in this document represent the state of engineering at the time of publishing.
We reserve the right to make modifications to the specifications and materials.

